

## »KIT DE HERRAJES CORREDIZO CANTILEVER (ALUMINIO).

**SCHEDA TECNICA AUTOPORTANTI SERIE 1000A (Alluminio)  
FINO A 8 METRI – PESO MAX DEL CANCELLO: 450 KG**

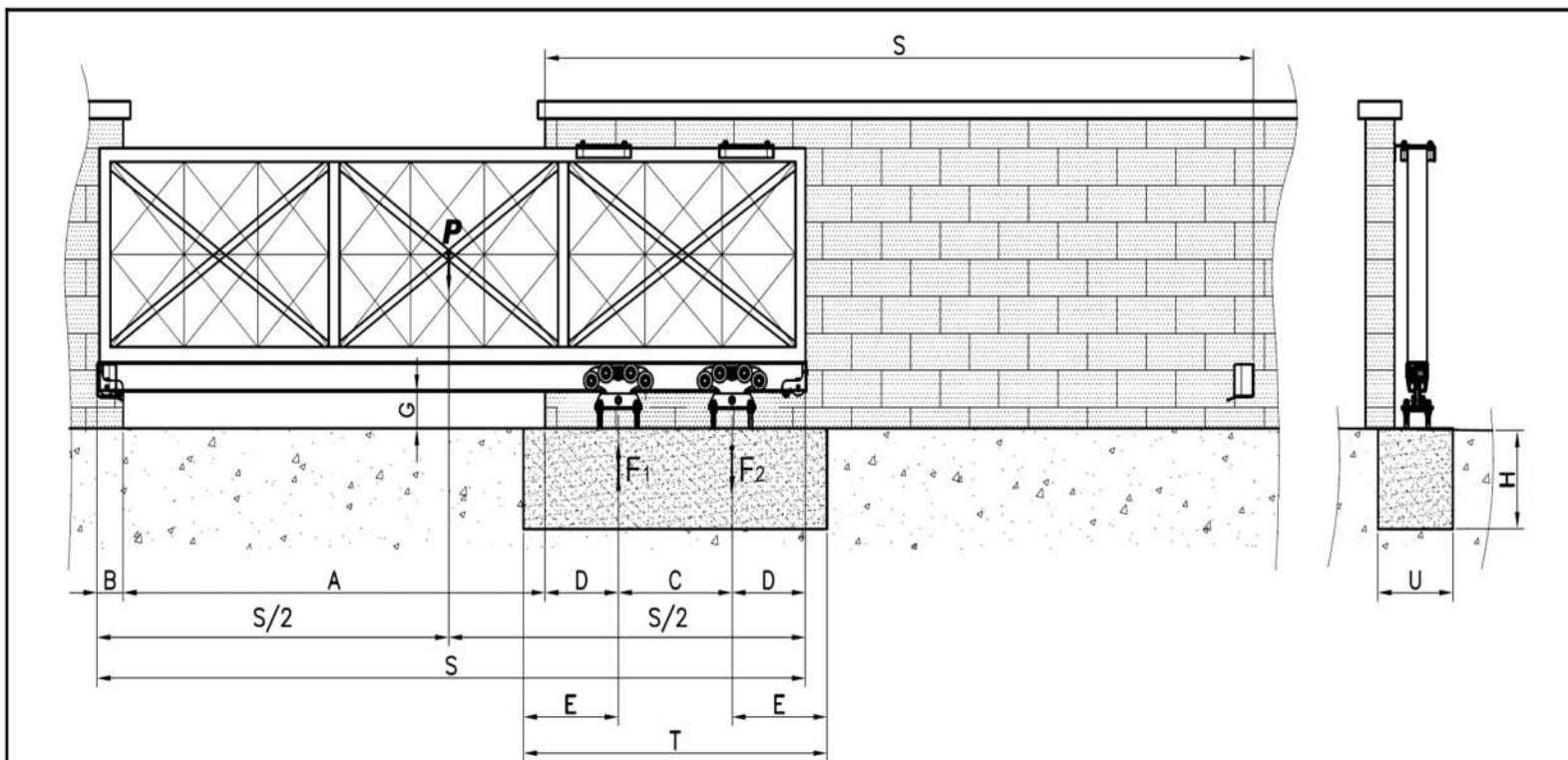
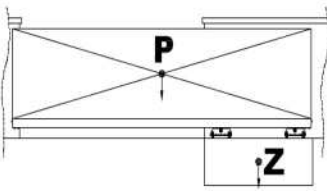
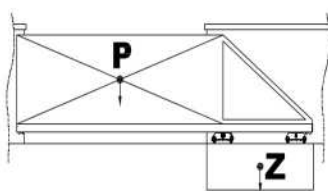

Dimensioni Dimensions			TxUxH min (m)	Carico uniforme (peso di tutta la lunghezza S) Uniform load (weight of total length S)			Carico non uniforme (peso del tratto A) Not uniform load (weight of overall opening A)		
A (m)	C (m)	S (m)		Pmax [kg] 450	Zmin [kg] 900	Pmax senza-Without acc. FAC (kg)	Pmax [kg] 350	Zmin [kg] 1200	Pmax senza-Without acc. FAC (kg)
3	1.20	4.7	1.80x0.50x0.50		425		325		
4	1.60	6.1	2.20x0.50x0.50		420		320		
5	2.00	7.5	2.60x0.50x0.50		410		310		
6	2.40	8.9	3.00x0.50x0.50		405		305		
7	2.80	10.3	3.40x0.50x0.50		400		300		
8	3.20	11.7	3.80x0.50x0.50		390		290		

Dati costanti-Fixed-data: F1max (kg) 800 ; D (m) 0,195 ; B (m) 0.155 ; Gmin (m) 0.06 ; Emin (m) 0.30

A/C=2.5



**Attention:** installations that do not comply with the illustrated procedure or failure to carry out correct maintenance operations can cause the gate to derail and endanger the safety of persons and property

(229) 288-1552

portonesautomaticos@adsver.com.mx  
portonesautomaticos@prodigy.net.mx









V07.17



## »KIT DE HERRAJES CORREDIZO CANTILEVER (ALUMINIO).

**SCHEDA TECNICA AUTOPORTANTI SERIE 1000A (Alluminio)  
FINO A 8 METRI – PESO MAX DEL CANCELLO: 450 KG**

Essenziale - <i>Essential</i>			Opzionale - <i>Optional</i>
 <b>2 x VD4101.100</b>	 <b>VD4200.100</b>	 <b>VD4202.100</b>	 <b>2kit x VD1701.014</b>
 <b>VD4406.100.A1</b>	 <b>VD1300.140</b>		

<b>Accessori complementari Complementary accessories</b>	 <b>VA3131.A30</b>	 <b>VA3105.A40</b>	 <b>VA3201.A30</b>	 <b>VA3207.B40</b>
	 <b>VA3302.A30</b>	 <b>VA3203.A30</b>	 <b>VA3206.A30</b>	 <b>VA6200.001</b>



**Attention:** installations that do not comply with the illustrated procedure or failure to carry out correct maintenance operations can cause the gate to derail and endanger the safety of persons and property

